

New Equipment Warranty

Limited Warranty

Jon-Don, Inc. warrants new equipment against defects in material and workmanship under normal use and service to the original purchaser. Any statutory implied warranties, including any warranty of merchantability or fitness for a particular purpose, are expressly limited to the duration of this written warranty. Jon-Don, Inc. will not be liable for any other damages, including but not limited to indirect or special consequential damages arising out of or in connection with the furnishing, performance, use or inability to use the machine. This remedy shall be the exclusive remedy of the purchaser. The warranty period is subject to the conditions stated below.

Lifetime Warranty on Body, 5 Years on Vacuum Motors and Pump, 2 Years on Heater, 1 Year on All Electrical Parts, 90 Days on Tools and Accessories

Jon-Don, Inc. warrants the roto-molded body to be free from defects in material and workmanship, under normal use and service for a lifetime. Jon-Don, Inc. warrants the motors and pump to be free from defects in material and workmanship, under normal use and service for five (5) years from the original date of sale, heater for two (2) years and all electrical parts one (1) year. Parts replaced or repaired under this warranty are warranted for the remainder of the original warranty period. Service labor charges are covered for one (1) year from the date of purchase, when performed by a Jon-Don Repair Center.

Labor is only provided by a Jon-Don Repair Center. If a Jon-Don Repair Center is not near you, it is the purchaser's responsibility to take their machine to a Jon-Don Repair Center.

Normal wear items, such as capacitors, cords, finishes or switches, will be warranted for manufacturing defects for ninety (90) days from the purchase date.

All warranties of motors and associated components will be voided: if the machine is serviced by anyone other than a Jon-Don Repair Center; if the machine is mechanically modified; if the machine is operated when not operating properly; or if the machine is misused or abused.

The warranty starts on the purchase date by the original purchaser from Jon-Don, Inc. subject to proof of purchase. The Machine Registration Card must be completed and returned immediately at the time of purchase. If proof of purchase cannot be identified, the warranty start date is ninety (90) days after the inventory stocking date at the distributor's warehouse.

Jon-Don

400 Medinah Road, Roselle, IL 60172

Phone: 800-556-6366 | Fax: 888-344-6878 | www.jondon.com

Make a copy of this card for future reference.

© 2019 All Rights Reserved Jon-Don, Inc.

SAFETY, OPERATION AND MAINTENANCE MANUAL WITH PARTS LIST

Please read before use!

150 PSI, 2-STAGE MOTOR



Model No. PE150

PROSPECTOR PE150 EXTRACTOR WITH HEAT

Jon-Don

IMPORTANT INFORMATION AND SAFETY INSTRUCTIONS

Serial No: _____



Manufactured with
Pride in the U.S.A.



Dear Valued Client,

Congratulations on the purchase of your Prospector 150 PSI Carpet Extractor! The world of floor cleaning is becoming more high-tech and competitive and we strive to provide you with the most innovative products. Our extractor is yet another example of this, bringing a new dimension to carpet cleaning with its cutting-edge features, quality and value.

Please review this manual paying careful attention to the Safety Instructions section. Keep in mind that any unnecessary damage, neglect or abuse of this machine will void your warranty. You can be confident that simple maintenance will ensure that your extractor provides quality performance for many years to come.

If warranty questions arise, please consult your manual or contact your Jon-Don representative. Should you have any questions regarding maintenance, replacing parts or ordering parts, please call your Jon-Don representative.

Before you begin using your extractor, thoroughly review the Owner's Manual.

Again, congratulations on the purchase of your Prospector 150 PSI Carpet Extractor!

Questions or Comments?

Phone: 800-556-6366

Fax: 888-344-6878

400 Medinah Road, Roselle, IL 60172

www.jondon.com

Jon-Don Warranty Registration

Please take a moment to register your machine. Fill out the information below and mail back to Jon-Don, Inc. immediately.

The warranty starts on the purchase date by the original purchaser, subject to proof of purchase. Please immediately register your machine by returning this Machine Registration Card at the time of purchase. If proof of purchase cannot be identified, the warranty start date is ninety (90) days after the inventory stocking date at the distributor's warehouse.

Machine Model _____ **Purchase Date** _____

Motor Type _____ **Serial No.** _____

Place of Purchase _____

Shipped To _____

Your Name _____ **Phone** _____

E-mail _____ **Fax** _____

Address Line 1 _____

Address Line 2 _____

City _____ **State** _____ **Zip** _____

Comments:

Mail to:
Jon-Don, Inc.
400 Medinah Road
Roselle, IL 60172

**See reverse side for warranty information.
Make a copy of this card for future reference.**

© 2019 All Rights Reserved Jon-Don, Inc.

PROSPECTOR PE 150 EXTRACTOR WITH HEAT

By Jon-Don, Inc.

Please fill out the following information:

Model No: _____

Serial No: _____

Distributor Name: _____

Distributor Phone No: _____

Date of Purchase: _____

Jon-Don

400 Medinah Road, Roselle, IL 60172

Phone: 800-556-6366 | Fax: 888-344-6878

www.jondon.com

New Equipment Warranty

Lifetime on body, 5 years on vacuum motors and pump, 2 years on heater, 1 year on all electrical components, 90 days on tools and accessories.

Warranty Policy

All equipment is inspected and tested before shipping from the manufacturer. All parts are warranted to be new and free from defects in workmanship and material, under normal use to the original retail purchaser. This warranty limits manufacturer's liability for defects in workmanship or materials for replacement of defective parts only. The manufacturer accepts no liability for incidental or consequential damages arisen from the use of any equipment, defective or not. This warranty is in lieu of all expressed or implied warranties and is extended only to the original retail purchaser. Manufacturer sales and service representatives are not authorized to waive or alter the terms of this warranty, or to increase the obligations of the manufacturer under the warranty. Parts replaced or repaired under this warranty are warranted for the remainder of the original warranty period.

Labor is only provided by a Jon-Don Repair Center. If a Jon-Don Repair Center is not near you, it is the purchaser's responsibility to take their machine to a Jon-Don Repair Center.

The manufacturer covers up to one (1) year (365 days) of service labor at the manufacturer's calculated hourly labor rate/repair time when performed by a Jon-Don Repair Center. Ultimately, labor reimbursement costs are at the discretion of the manufacturer. At no time is the manufacturer responsible for travel time to complete on-call repairs. After one (1) year, the original retail purchaser is responsible for all labor costs with no manufacturer reimbursement.

The original purchaser must contact the manufacturer to follow correct RMA/warranty procedures. They must include a copy of the RMA Sheet enclosed in the box with the returned item. No returns shall be authorized unless the proper RMA procedures are followed. It is the responsibility of the distributor to repair the client's equipment as soon as possible.

Items being returned must be new, unused, free of damage and are only good for up to 30 days. After 30 days, the manufacturer does not accept the return of any items for a store credit.

Authorized warranty replacement parts need to come directly from the manufacturer. Any use of any other parts will void warranty. The manufacturer does not reimburse for parts used by client that were not supplied directly for the machine under warranty.

The client must contact the manufacturer prior to working on or changing out any parts, etc. The manufacturer must issue an RMA Sheet containing approved labor time and replacement parts. Do not send parts or equipment back to the manufacturer without an RMA Number and approval. No labor will be paid for, nor parts cost paid for or reimbursed, that have not previously been approved by the manufacturer. All warranty work must be approved and authorized to qualify, and appropriate warranty procedures must be followed.

The warranty starts on the purchase date by the original purchaser from Jon-Don, subject to proof of purchase. The Machine Registration Form must be completed and sent to the original manufacturer at the time of purchase. If proof of purchase cannot be identified, the warranty start date is ninety (90) days after the date of sale to an authorized distributor.

1.0 Safety Instructions

READ THIS MANUAL BEFORE OPERATING MACHINERY. KNOW THE PROPER SETUP, OPERATION, CORRECT APPLICATIONS AND THE LIMITATIONS OF THIS EQUIPMENT **BEFORE** USE.

This carpet extractor will afford you many years of trouble-free operating satisfaction, provided it is given the proper care. All parts have passed rigid quality control standards throughout the assembly process. Prior to packaging, your carpet extractor was again inspected for assurance of flawless operation.

This machine is protectively packed to prevent damage in shipment. We recommend that upon delivery, unpack the unit and inspect it for any possible damage. Only a visual inspection will reveal damage that may have occurred.

If damage is discovered, immediately notify the transportation company that delivered your equipment. As a shipper, we are unable to report any claim for damage. You must originate any claim within five (5) days.

This manual is for your protection and information. Please read carefully since failure to follow precautions could result in discomfort or injury.

Reduce the Risk of Fire, Electric Shock or Injury

Use only as described in this safety operating manual. Use only the manufacturer's recommended attachments, accessories, replacement parts and filters. Replace damaged or worn parts immediately with genuine, original equipment parts to maintain safety and to protect your limited warranty.

Always turn OFF the carpet extractor before connecting, disconnecting or working on the machine. This equipment must be connected to a properly grounded outlet only (see grounding instructions). (2) 25-foot, 12/3-gauge safety power cords are provided with this unit (dependent on the model) and **MUST** be used with this unit to ensure grounding protection. Turn off all controls before unplugging. Make sure the on/off switch is in the off position. This is not a toy. Close attention is necessary when used around or near children. Use extra care when cleaning on stairs.

11.0 Machine Parts List – No Heater Continued

Drawing No.	Item ID	Item Description	Qty.
51	10-0814	Sensor for Extractor Heater	4.00
52	10-1500-C	Heater Element 875 Watt	2.00
53	80-0022-A	Screw for Panel	2.00
54	10-0921	Aluminum Box for Dual Rod Heater	1.00
55	10-0204	Motor Mount Backup Washer	4.00
56	80-0022-A	Screw for Panel	4.00
57	10-0920	Dual Rod Heat Exchanger Tube	1.00
58	80-0101-M	1/4" Male Check Valve	1.00
59	10-0801-I	90 FPT for Exchanger Tube	1.00
60	80-0011-2	90 Degree Street Elbow	1.00
61	10-0907	Strain Relief for Tube Heater	1.00
62	10-0901	175 PSI Relief Valve for Heater	1.00
63	80-0010	1/4" Brass Tee	1.00
64	10-0868	1/4" Female QD for Extractor	1.00
65	10-0843	3/8" Black Hose for Extractor	6.00
66	10-0835-B	Pump Bolt 100 PSI Extractor	4.00
67	10-0867	150 PSI Extractor Pump	1.00
68	10-0843	3/8" Black Hose for Extractor	6.00
69	10-0801-J	90 MPT for Extractor Heater	1.00
70	10-0846	1/4" MPT Hex Nipple for Extractor	1.00
71	10-0356	3/8 MPT x 3/8 Barb 90 Degree	2.00
72	80-0017	Bulk Head Fitting for Extractor	2.00
73	80-0017	Bulk Head Fitting for Extractor	2.00
74	10-0843	3/8" Black Hose for Extractor	6.00
75	10-0400-C	Keeper Latch for Extractor	1.00
76	10-0818	S/R Top of Tank Bolt on Extractor	2.00
77	10-0832	S/R Strap Bolts	4.00
78	10-0831	S/R Bracket for Extractor	2.00

11.0 Machine Parts List – with Heater

Drawing No.	Item ID	Item Description	Qty.
1	SN-12-ST-BLUGRAN	12-Gallon Solution Tank - Blue Granite	1.00
2	10-0479	1/4" Male Close Nipple	1.00
3	10-0845	1/4" Strainer for Extractor	1.00
4	SN-12-L-BLUGRAN	12-Gallon Lid - Blue Granite	1.00
5	80-0001	Extractor Exhaust Hose	0.30
6	10-0843	3/8" Black Hose for Extractor	6.00
7	10-0826	3/4" Hose Clamp for Extractor	6.00
8	80-0026	3/8 Barb x 1/4 MPT 90 Degree	3.00
9	10-0806	Barb Hose Fitting for Extractor	1.00
10	10-0379	8-32 x 3/8 Screw	8.00
11	10-0204	Motor Mount Back-Up Washer	18.00
12	10-0803	Splash-Proof Switch for Extractor	3.00
13	10-0803-H	Splash-Proof Heater Switch	1.00
14	10-0809-A	Extractor 4-Hole Switch Plate	1.00
15	80-0200-C2100H-3100H	Extractor Wire Harness	1.00
16	SN-12-RT-BLUGRAN	12-Gallon Recovery Tank - Blue Granite	1.00
17	80-0008	1.5 PVC Female Adapter	1.00
18	10-0416-A	1-1/2" Black ABS Stand Pipe	1.30
19	10-0804-A	Hatch Cover Gasket for Extractor	1.00
20	10-0804	Hatch Cover for Extractor	1.00
21	10-0419-A	Screw for Extractor Hatch	12.00
22	80-0012	Shut-Off Assembly for Extractor	1.00
23	10-0805	Dump Valve for Extractor	1.00
24	10-0024	1-1/2" Black Vacuum Hose	1.60
25	10-0849	1-1/2" ABS Fitting	1.00
26	10-0848-B	1-1/2" 90 Degree ABS Street Elbow	3.00
27	10-0811	2-Stage Extractor Motor	2.00
28	10-0838	Pigtail for Extractor	2.00
29	10-0850	Strain Relief for Extractor	2.00
30	10-0851	Strain Relief Nut for Extractor	2.00
31	10-0822	Exhaust Grate for Extractor	3.00
32	10-1030-S2	2-Stage Extractor Motor Gasket	2.00
33	SN-12-MFLD	Extractor Motor Manifold	2.00
34	10-0023	Shoulder and Waist Belt Washer	4.00
35	10-0833	Motor Manifold Bolts for Extractor	10.00
36	10-0830	Hinge Keeper for Extractor	2.00
37	10-0821	Extractor Hinge	2.00
38	10-0820	End Cap for Rod on Extractor	4.00
39	SN-12-MB-BLKGRAN	12-Gallon Motor Base - Black Granite	1.00
40	10-0836	19" Axle for Extractor	1.00
41	10-0807	Wheels for Extractor	2.00
42	10-0840	Nylon Washer	8.00
43	10-0835-N	Nut for Pump Bolt on Extractor	4.00
44	10-0834	Pump Flat Washer	14.00
45	10-0808	Caster for Extractor	2.00
46	10-0816	Caster Bolt	8.00
47	10-0400-D	Latch for Extractor	1.00
48	10-0379	8-32 x 3/8 Screw	8.00
49	80-0040	3000 PSI Hose for Extractor	4.50
50	10-0852	1/4" 90 Degree Brass Elbow	2.00

1.0 Safety Instructions Continued

Reduce the Risk of Fire, Electric Shock or Injury.

- DO NOT leave the carpet extractor while plugged in. Unplug it from the outlet when not in use and before servicing.
- DO NOT use this carpet extractor with a damaged cord or plug. If the equipment is not working as it should because it has been dropped, damaged, left outdoors, etc., contact an authorized service center.
- DO NOT unplug the carpet extractor by pulling the cord. To unplug, grasp the plug, not the cord. DO NOT pull the unit by the cord, use the cord as a handle, close a door on the cord, or pull the cord around sharp edges or corners. Keep the cord away from heated surfaces. Lift using only the appropriate handles.
- DO NOT overstretch the safety power cord between the equipment and the electrical outlet in the wall.
- DO NOT tie an extension cord to the pigtail cord. This will damage the cord and will VOID your warranty.
- DO NOT handle the plug of the vacuum with wet hands.
- DO NOT move the machine up or down stairs with fluid in the machine.
- DO NOT pick up anything that is burning or smoking, such as cigarettes, matches or hot ashes.
- DO NOT use the machine to pick up flammable or combustible liquids, such as gasoline, or use in areas where they may be present.
- DO NOT use where oxygen or anesthetics are used.
- DO NOT put objects into openings or use with any openings blocked. Keep free of dust, lint, hair and anything that may reduce airflow. Keep hair, loose clothing, fingers, and all body parts away from openings and moving parts to ensure safe operation.
- DO NOT use if any hoses or nozzles are damaged, cut or punctured.
- DO NOT expose to rain or use on wet surfaces, to avoid electric shock. Store indoors.
- DO NOT leave machine outdoors, in extreme heat or cold. Harsh weather elements will damage components and void warranty.
- DO NOT lubricate the motor. If the motor is lubricated, this will VOID your warranty.

2.0 Grounding Instructions

DANGER: IMPROPER INSTALLATION OF THE GROUNDING PLUG CAN RESULT IN A RISK OF ELECTRIC SHOCK!

This product must be grounded. In the event of an electrical short circuit, grounding reduces the risk of electric shock by providing an escape wire with an appropriate grounding plug. The plug must be plugged into an outlet that is installed properly and grounded in accordance with all local codes and ordinances.

Check with a qualified electrician or serviceman if the grounding instructions are not completely understood, or if in doubt as to whether the product is grounded properly. DO NOT modify the plug provided. If it will not fit into the outlet, have a proper outlet installed by a qualified electrician.

2.0 Grounding Instructions Continued

This electric equipment is for use on a normal 120-volt circuit. It has a grounded plug that looks like the plug illustrated in (Fig A). The use of a temporary adaptor is NOT recommended.

NOTE: In Canada, the use of a temporary adaptor is not permitted by the Canadian Electrical Code.

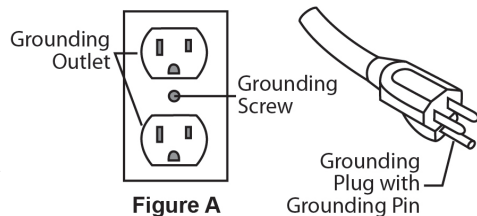

3.0 Care of your Carpet Extractor

Treat your machine as you would any other high-grade, precision-made product. Dropping, unreasonable bumping across thresholds and other misuses may result in a damaged unit which will not be covered under warranty.

After each use, wipe the extractor body, accessories and power cord with a slightly damp cloth. When not in use, remove the power cord and hoses. Store in a dry area.

4.0 Setup and Operation

DO NOT USE ON WET SURFACES. DO NOT EXPOSE TO RAIN. STORE INDOORS.

All carpet extractors, no matter what the time of year, are shipped with antifreeze in the solution lines. Prior to first use, fill the tank with one quart of warm water. Attach the hose and using the hand tool wand, flush out the system by spraying the one quart of water through the pump.

- Attach the 1-1/2-inch vacuum hose and the brass quick disconnect.
- Fill the recovery tank with warm water (less than 100 degrees Fahrenheit). Fill to approximately 4 inches from the top. Pre-spray a liquid detergent made for carpet cleaning or upholstery on carpet and agitate carpet. Next, use clean water from solution tank to extract – this procedure is highly recommended. Note: read and mix your pre-spray solution to the dilution ratios as directed.
- Be sure to replace any filters back into the machine prior to use.
- DO NOT use citrus acid, buterol or harsh degreasers inside the machine.
- DO NOT use powdered detergents in this machine – will VOID warranty.

10.0 Machine Schematic Drawing – with Heater

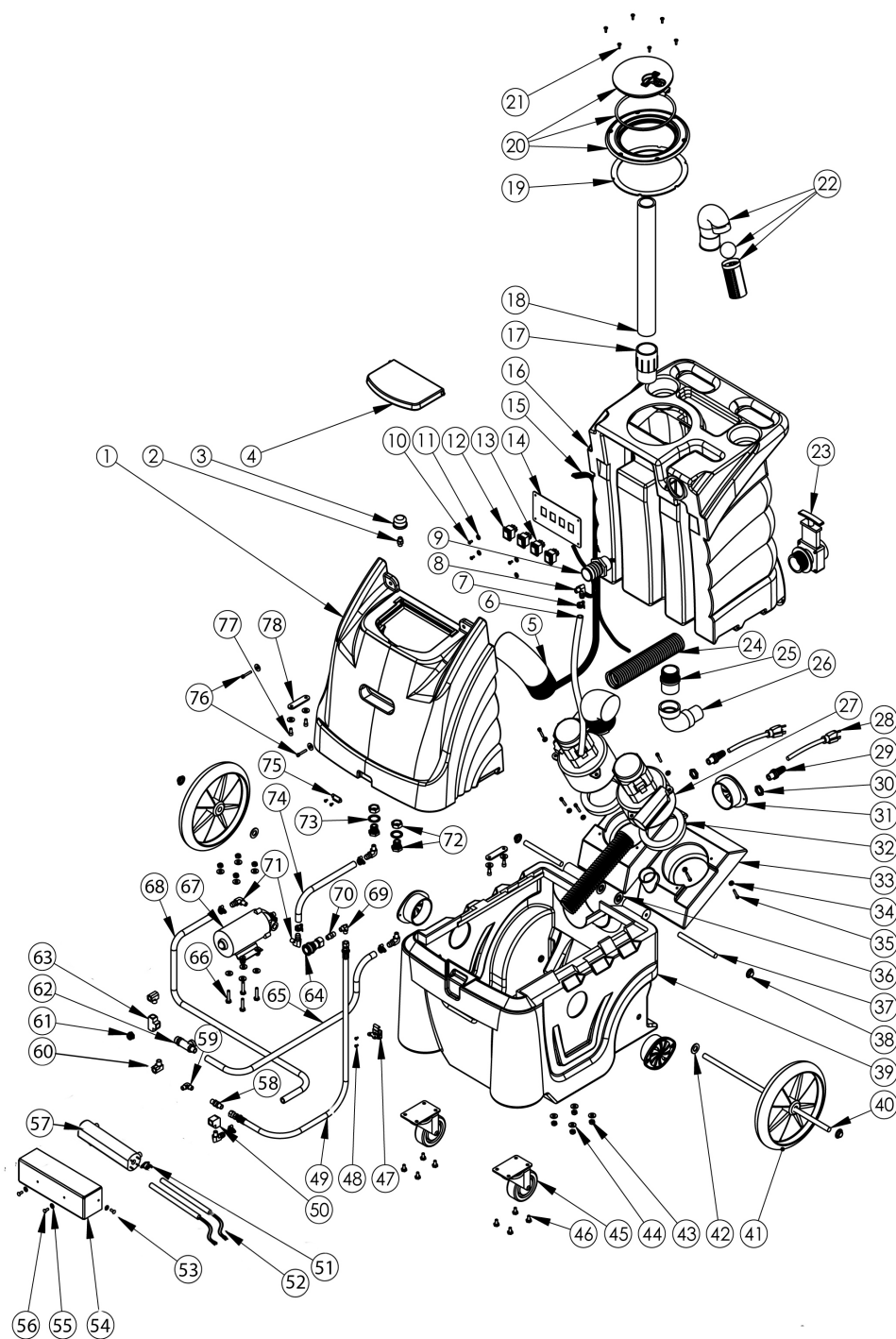

9.0 Machine Wiring Diagrams

9.1 Carpet Extractor - with Heat

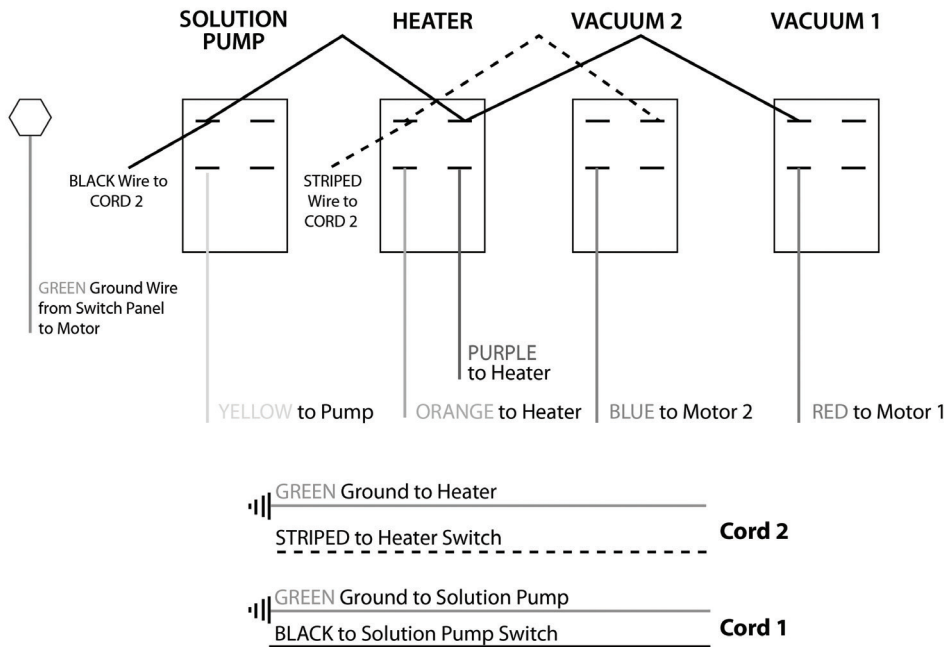

4.0 Setup and Operation

4.2 Vacuum System

The extractor uses a dual-vacuum motor system that provides outstanding water lift and airflow.

Vacuum Float Assembly Warning System:

The float assembly shut-off, located in the recovery tank on the vacuum stand pipe, prevents the waste tank from overflowing into the stand pipe and damaging the vacuum motor. The float assembly will cut off vacuum to the waste tank. The motor will also reach a fast, high-pitched sound alerting you when the recovery tank is about to overflow. When this happens, immediately turn off the vacuum motor and empty the waste tank. If the operator continues to use machine after the tank is full, it will VOID the Warranty.

The float assembly has a filter to prevent debris from entering the stand pipe. Refer to the “Maintenance” section for removal and proper cleaning. It is also necessary to use low-foaming chemicals or a defoamer to eliminate foam buildup in the recovery tank and damage to the vacuum motors.

If moisture enters the vacuum motors, contact an authorized service center. To prevent moisture from damaging the vacuum motors during storage, empty the recovery tank and store with the lid open.

4.3 Power Priming the High-Pressure Pump

Once water is in the solution tank, the high-pressure pump must be primed:

- Turn ON both vacuums then the solution pump. The vacuum will pull solution through the pump and prime valve into the vacuum tank.
- Place the end of priming hose inside the vacuum hose barb.
- Cup a hand around the hose and barb to increase the vacuum suction on the hose. When the pump is primed, you will hear the pulsation of the pump change.
- After priming, turn OFF the solution pump. If you have not yet connected your solution hose or tool, you may have to relieve the pressure in the line so you can connect your hose or tool.

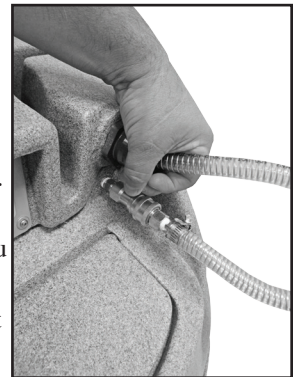

If the pump still does not prime or if flow is low or unsteady, check the hose from the solution tank to the pump (as well as the filter) for clogging, kinks, or restrictions. Clean or replace hose and/or filter and repeat the priming process.

If you are having trouble with the pump, refer to the “Troubleshooting Guide” section or contact Jon-Don for advice or assistance.

5.0 Maintenance

WARNING: Disconnect electrical power cord before performing any service or maintenance inside the machine base or before testing or repairing switches or power cords. Failure to do so may result in severe personal injury or death.

Regular maintenance is required to keep your Carpet Extractor in proper working condition. Failure to properly maintain your machine could void warranty. Thoroughly clean all equipment and accessories after each use:

- Rinse the solution and recovery tanks with clean water.
- Flush the pump system with clean water, including all hoses and wands.
- Do not allow water to remain in the tanks after use.
- Lubricate all quick disconnects with WD-40 or similar lubricant.
- Clean vacuum float assembly screen.

Operation	Interval
Clean Fresh Water Tank Filter	Daily - After Each Job
Clean Vacuum Assembly Screen	Daily - After Each Job
Rinse Out Recovery Tank	Daily
Clean Pump Inlet Filter	Weekly - As Needed
Clean Dump Valve	Weekly - As Needed
WD-40 Vacuum Motors	Weekly - As Needed
Prevent Mineral Deposit Buildup	Every Two Weeks

5.1 Clean Vacuum Float Assembly Screen

Inside the recovery tank, on top of the stand pipe, is the vacuum float assembly. It functions to prevent debris and water from being sucked into the vacuum motors. Operating the equipment without the float assembly or with a poorly maintained assembly will greatly decrease the life of the vacuum motor and will VOID your warranty.

If debris builds up on this filter, it will reduce the vacuum airflow and may cause a significant decrease in the rate of water recovery. If debris prevents the float ball from moving or seating inside the assembly, it may not stop the airflow when the tank fills with water and water will be sucked in the vacuum and blow out the exhaust.

To clean, twist off the float assembly from the stand pipe and clean the screen. Pull fibers and lint off and rinse with clean water. Push the assembly back onto the stand pipe and replace the recovery tank lid.

This screen should be cleaned daily, especially if the carpet extractor is being operated in an environment which has an abnormal buildup of lint and debris, such as cleaning newly installed carpet. Loss of vacuum is most normally associated with lint buildup in this filter at the top of the vacuum stand pipe.

(8) Prospector PE150 Carpet Extractor with Heat

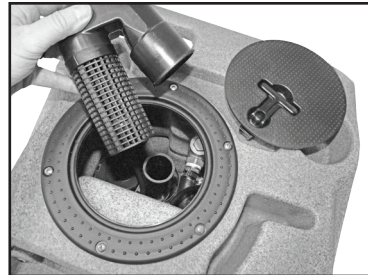

Vacuum Shut-Off Assembly

8.0 Troubleshooting Guide

CAUTION: Always disconnect the power cord before servicing equipment.

WARNING: Never operate this carpet extractor when the equipment is not performing as expected or when any part is visibly damaged. Repairs should only be performed by an authorized service center. Failure to do so will VOID warranty.

System	Problem	Possible Cause	Remedy
Vacuum System	No Vacuum / Weak Vacuum	<ol style="list-style-type: none"> 1. Vacuum Tank Full 2. Float Assembly Tank Screen Dirty 3. Float Ball Stuck 4. Damaged or Loose Vacuum Hose 5. Dump Valve Open 6. Access Lid Not Sealed 7. Vacuum Hose Clogged 8. Air Intake Grid Clogged 9. Leak in Recovery Tank 10. Water Coming Out of Vacuum Exhaust 	<ol style="list-style-type: none"> 1. Empty Tank 2. Clean the Screen with Water 3. Tap Float to Unstick then Clean 4. Attach or Replace 5. Close Valve 6. Replace Gasket 7. Clear Debris 8. Clean 9. Clean and Dry Area, Patch with Silicone 10. Use a Low-Foaming Detergent
	Unit Will Not Turn On	<ol style="list-style-type: none"> 1. Extension Cord Not Plugged In 2. Switch Not in the "On" Position 3. Building Circuit Overloaded 4. Wiring Connections Loose 	<ol style="list-style-type: none"> 1. Check if Machine and Cord are Plugged In 2. Check Switches, Replace if Necessary 3. Reset Circuit 4. Unplug Machine and Check for Loose Wires
Electrical System	Burning Smell	<ol style="list-style-type: none"> 1. Vacuum Motor Hung Up 2. Pump Motor Hung Up 	<ol style="list-style-type: none"> 1. Replace Vacuum Motor 2. Replace Pump
	Pump is Not Running Properly	<ol style="list-style-type: none"> 1. No Power to the Pump 2. Jets on Wand are Clogged 3. In-Line Water Filter is Clogged 4. Debris in Solution Tank Covering Inlet 5. Kinked or Loose Hose 6. Pump Failed 7. Quick Disconnects Are Not Completely Locked Together 8. Heater is Clogged with Deposits 9. Pump is Pulsating 10. Auto Prime Valve is Open 	<ol style="list-style-type: none"> 1. Check the Electrical System 2. Clean Jet Filters 3. Clean In-Line Filter 4. Clear Debris 5. Check and Replace Hoses if Necessary 6. Replace Pump 7. Snap Quick Disconnects Together 8. Flush Heater with System Maintainer or Replace if Necessary 9. Check for Clogged Jets and Clean 10. Close Valve
Pump System			

7.0 Storing Your Carpet Extractor

Store your carpet extractor in temperatures over 40 degrees Fahrenheit. To prevent moisture from damaging the vacuum motor during storage, empty the recovery tank and store with the lid open. Store in an upright position in a dry area.

If you plan on storing your extractor in freezing conditions or for a long period of time, you must winterize your carpet extractor to protect the pump from freezing or damage being caused to fittings and valves. Damage due to freezing is NOT covered under the warranty. The following procedure should help prevent your carpet extractor from freezing and prevent pump and seals from drying out.

Recommended Procedure for Storage

- Pour a quart of RV Water System Antifreeze into the solution tank.
- Connect the solution hose to the front of the machine.
- Use the wand to spray the mixture into a bucket.
- Vacuum the excess mixture out of the solution tank and into the recovery tank. Dispose of the antifreeze properly.

To return to service, flush the pressure system by repeating the above steps, using fresh water in place of antifreeze.

5.0 Maintenance Continued

5.2 Rinse Out Recovery

Buildup of fine silt and debris can damage the auto-dump pump and dump valve. Cleaning out the recovery tank on a regular basis will extend the life of these components, as well as keep the tank and machine smelling better. To rinse out recovery tank, remove the recovery tank lid and open the dump valve. Place a bucket under the dump valve. Use a hose to rinse the dirt and debris out of the recovery tank. Close the dump valve and spray the tank with deodorizer or disinfectant. Proceed to waste pump cleaning and replace the recovery tank lid. Dispose of dirty water and debris.

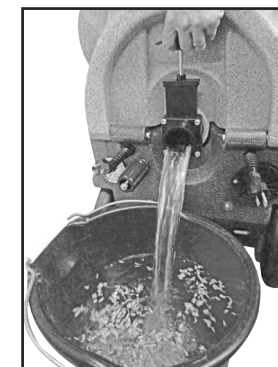
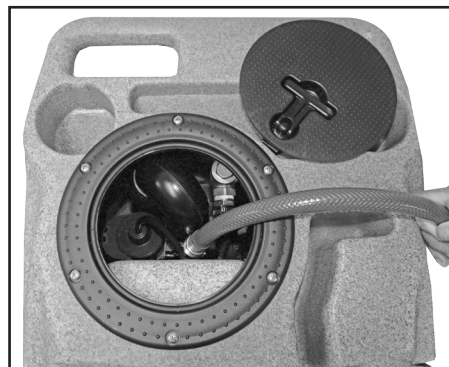

5.3 Clean Pump Inlet Filter

CAUTION: Before proceeding with this procedure, make sure both the power cords are disconnected.

- To examine the filter, open the solution tank lid on the front of the machine. The filter is in the bottom of the solution tank.
- Grasp the filter cap and unscrew the filter from the brass nipple by turning counter-clockwise. Clean the filter by rinsing with fresh water. If necessary, use a toothbrush to remove detergent buildup. Replace as needed.

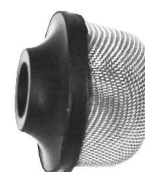

NOTE: Heavy buildup is a warning sign that the solution system should be flushed.

5.0 Maintenance Continued

5.4 Clean Dump Valve

The dump valve, located on the back of the machine, has a track inside of it. Open the dump valve and check the track for buildup. This buildup could prevent the dump valve from closing and cause leaking. Use a toothbrush to clean the track of the dump valve.

5.5 WD-40 Vacuum Motors

Should moisture ever enter the vacuum motors, completely drain the recovery tank, open the recovery tank lid, remove the vacuum float assembly, turn on the vacuum motor and spray a burst of WD-40 into the standpipe. Continue to run the vacuum motor for at least three (3) minutes.

To prevent moisture from damaging the vacuum motors during storage, empty the recovery tank and store with the lid open.

5.6 Prevent Mineral Deposit Buildup

Vinegar may be used to prevent mineral deposit buildup in your machine's lines and pump. Failure to do so may clog your lines and pump. Every two weeks, pour vinegar into the solution tank (dilute with 1/2 water). Run the pump, while squeezing your wand or upholstery tool's trigger until you smell vinegar or notice it coming out of the tool. Let the machine sit overnight, and no longer, with the vinegar in its lines. The next day, flush the machine with 1 gallon of clean water or until you do not smell vinegar any longer.

PLEASE NOTE: If you choose to use CLR, follow the directions on the bottle. **DO NOT** leave CLR in the machine's lines and flush thoroughly. CLR may corrode the machine's components and **VOID** your warranty. If you choose to use vinegar, you **MUST** dilute with 1/2 water. Failure to do so may damage the machine's components and **VOID** your warranty.

6.0 Shutdown Procedures

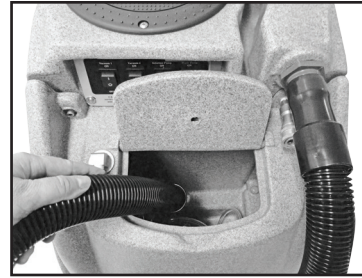

Figure 1

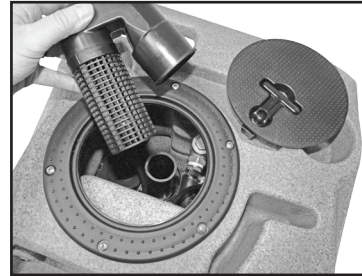

Figure 2

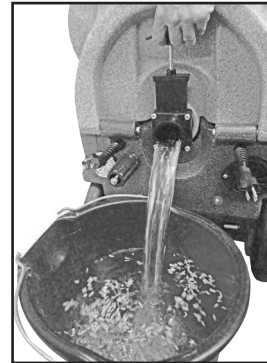

Figure 3

- When finished cleaning, turn OFF all switches.
- Disconnect the solution hose and vacuum hose from the cleaning tool. Pull the valve trigger to release pressure from the hose before disconnecting the solution hose from the cleaning tool.
- If water remains in the solution tank, use the vacuum hose and vacuum the excess water from the tank (Figure 1).
- Disconnect the power cords from the outlets and from the machine.
- Remove the float assembly from the recovery tank and clean filter as needed. Replace float assembly and tank lid (Figure 2).
- Drain any remaining water from the recovery tank and dispose of in a sanitary drain. **CAUTION:** use separate buckets to drain and fill the tank. Even the smallest debris can cause issues (Figure 3).
- Disconnect and roll up all hoses and tools. Store machine and accessories in a dry space.